

2-Dimensional Current Meter

A compact, cost-effective meter with vector-averaged current speed and direction

The Falmouth Scientific, Inc. 2-Dimensional Acoustic Current meter represents the state of the art in acoustic current meter design.

Utilizing ultra-low-power solid-state design, the 2D ACM offers a very compact, lightweight measurement tool capable of high-accuracy horizontal current measurement. With internal data logging capability, long-term battery operation, internal electronic compass and tilt sensors, the 2D ACM is well suited for a broad variety of measurement applications.

The instrument is available in either shallow-water plastic, or deep-water titanium housings. The 2D ACM also has the capability of adding a CTD module and can log up to two analog inputs from external sensors (e.g., DO, OBS, Fluorometer, Transmissometer).

FEATURES

- Compact, lightweight, low-maintenance construction
- Simple to operate
- 2-axis true cosine response velocity measurement
- Accurate velocity measurement with excellent low-velocity resolution
- Electronic magnetoresistive compass with 2-axis tilt sensor
- Temperature measurement capability
- Extremely long battery life with low-maintenance alkaline batteries
- Real-time output/display capability
- Long-term data logging to internal flash memory
- ASCII serial data output via RS-232 or RS-485
- Built-in real-time clock with on/off power control
- 1.5-ton working strength mooring frame (optional 3-ton mooring frame)
- Optional conductivity, temperature, pressure sensor package may be added
- Choice of epoxy shallow-water or titanium deep-water housing



2D ACM with optional 3 ton frame

SPECIFICATIONS

Sensors

Parameter	Type	Range	Accuracy	Resolution
Velocity	Acoustic	0 to 600 cm/s	2% of Reading or 1 cm/s	0.01 cm/s
Direction	3 Axis Magnetometer	0 to 360°	±2°	0.01°
Tilt	2 Axis Accelerometer	0 to 45°	0.5°	0.01°
Temperature	Semi-Conductor	-2 to 35°C	0.5°C	0.5°C, .05°C*

*Optional

Optional CTD

	Range	Accuracy	Resolution	Stability
Conductivity (S/m)	0 to 7.0	±0.002	.0001	±0.005
Temperature (Celsius)	-5° to 32° ITS-90	±0.03°	.001°	±0.005°
Pressure (dBar)	0 to 200 dBar 0 to 2000 dBar	±0.3% full scale	0.01% full scale	±0.01% full scale

Instrument

External Power:	9 to 28 VDC, 12 mA (ACM Only), 32 mA (ACM with CTD)
Battery Power:	Alkaline 5 D Cell Welded Pack, 10 AHR, Operating Range: 6-8 VDC
Sample Rate:	2 Hz Maximum
Vector Averaging Period:	15 Seconds to 54 Minutes
Depth Rating/Physical Material:	200 Meter Epoxy Housing Standard 7000 Meter Titanium Housing Optional
Mooring Frame:	1.5 Ton 316 Stainless Steel Mooring Frame Standard 3 Ton Stainless Steel Mooring Frame Optional
Real Time Clock:	Programmable Sampling/Low-power Mode
Input Channels:	Two (2) DC Input Channels Available for Other Sensor Input, such as Transmissometer DO, OBS (Regulated 12 VDC Output to Power Other Sensors)
Weight:	Air: 8 lbs/3.63 Kg (200 Meter Version) Air: CTD 1.54 lbs/.7 Kg Water: 4 lbs/1.81 Kg (200 Meter Version)

Specifications Subject to Change without Notice

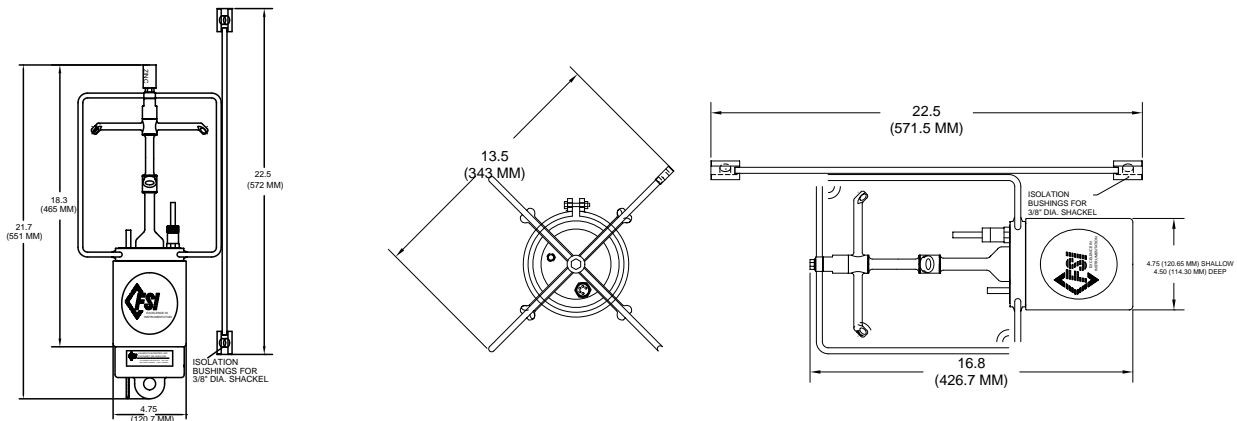

March 2003

Falmouth Scientific, Inc.

1400 Route 28A, PO Box 315, Cataumet, MA 02534-0315

Email: fsi@falmouth.com • Tel: 508-564-7640 • Fax: 508-564-7643 • www.falmouth.com