

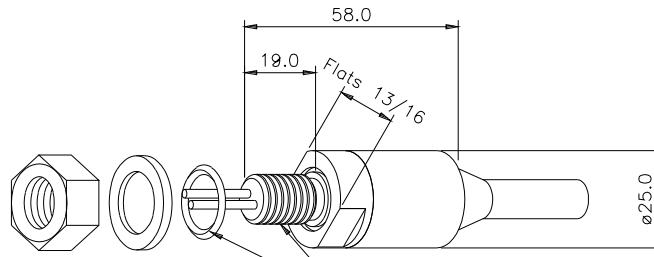

PNAST 7/16"
 PNASt 1/2"
 PNASt 5/8"



7/16"x20UNF / O-Ring 12.42x1.78 (2-014)
 1/2"x20UNF / O-Ring 14.00x1.78 (2-015)
 5/8"x18UNF / O-Ring 17.17x1.78 (2-017)

PNARA 3/8"
 PNARA 7/16"
 PNARA 1/2"

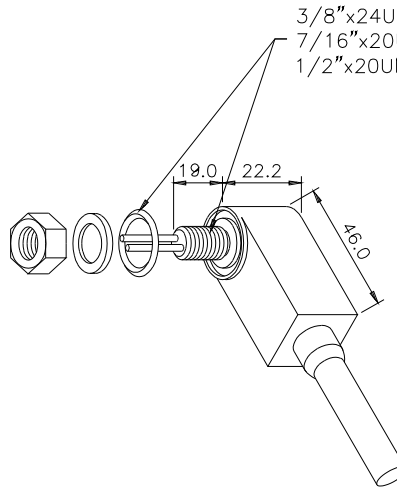

3/8"x24UNF / O-Ring 12.42x1.78 (2-014)
 7/16"x20UNF / O-Ring 12.42x1.78 (2-014)
 1/2"x20UNF / O-Ring 14.00x1.78 (2-015)

PNARA 3/4"

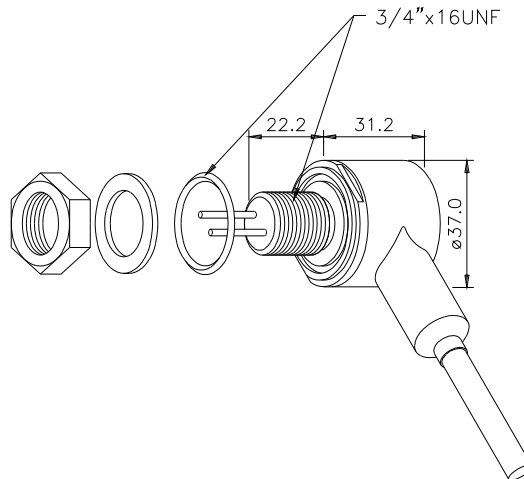

3/4"x16UNF / O-Ring 25.12x1.78 (2-022)

	<p>Penetrator Specification</p> <p>Insulation Resistance : >200 megaohm Temp. Rating : -4 to +60 degr. C Depth Rating : 500 bar - 7.000 psi</p>	<p>Standard Material Specification</p> <p>Connector Body : Neoprene (CR) Bulkhead Body : Stainless steel Leads (30 cm) : 18 AWG 1,0 mm² Teflon</p>	<p>Dimensions in mm. Threads in inches. 1 inch = 25.4 mm. 1 mm = 0,03937 inch.</p> <p>Modification rights reserved</p> <p>Drawing No. SE 300-26</p>
--	---	--	--